

SEMPACK® 3 Thyristor/ Diode Modules

SKKT 213 **SKKH 213**
SKKT 253 **SKKH 253**



V _{RSM}	V _{RRM} V _{DRM}	(dv/dt) _{cr}	I _{T(RMS)} (maximum values for continuous operation)			
			370 A	420 A		420 A
V	V	V/μs	I _{TAV} (sin. 180; T _{case} = 85 °C)			
			230 A	250 A		250 A
			SKKT	SKKT	SKKH	SKKH
900	800	500	213/08 D	253/08 D	–	253/08 D
1300	1200	1000	213/12 E	253/12 E	213/12 E	253/12 E
1500	1400	1000	213/14 E	253/14 E	213/14 E	253/14 E
1700	1600	1000	213/16 E	253/16 E	213/16 E	253/16 E
1900	1800	1000	213/18 E	253/18 E	213/18 E	253/18 E
2100	2000	1000	213/20 E	–	213/20 E	–
2300	2200	1000	213/22 E	–	213/22 E	–

Symbol	Conditions	SKKT 213 SKKH 213	SKKT 253 SKKH 253	Units
I _{TAV}	sin. 180; (T _{case} = ...)	213 (90 °C)	253 (85 °C)	A
I _D	B2/B6 T _{amb} = 35 °C;	354/456	387/502	A
I _{RMS}	W1/W3 P 16/200 F	425/3x360	465/3x400	A
I _{TSM}	T _{vj} = 25 °C; 10 ms T _{vj} = 130 °C; 10 ms	8 500 A 7 500 A	9 000 A 8 000 A	A
i ² t	T _{vj} = 25 °C; 8,3 ... 10 ms T _{vj} = 130 °C; 8,3 ... 10 ms	361 000 281 000	405 000 320 000	A ² s A ² s
t _{gd}	T _{vj} = 25 °C; I _G = 1 A; di _G /dt = 1 A/μs		1	μs
t _{gr}	V _D = 0,67 · V _{DRM}		2	μs
(di/dt) _{cr}	T _{vj} = 130 °C		250	A/μs
t _q	T _{vj} = 130 °C		typ. 50 ... 150	μs
I _H	T _{vj} = 25 °C		typ. 150; max. 500	mA
I _L	T _{vj} = 25 °C; R _G = 33 Ω		typ. 0,3; max. 2	A
V _T	T _{vj} = 25 °C; I _T = 750 A	max. 1,9	max. 1,7	V
V _{T(TO)}	T _{vj} = 130 °C	0,95	0,85	V
r _T	T _{vj} = 130 °C	1,3	1,1	mΩ
I _{DD} ; I _{RD}	T _{vj} = 130 °C; V _{DD} = V _{DRM} ; V _{RD} = V _{RRM}	50	50	mA
V _{GT}	T _{vj} = 25 °C; d. c.		3	V
I _{GT}	T _{vj} = 25 °C; d. c.		200	mA
V _{GD}	T _{vj} = 130 °C; d. c.		0,25	V
I _{GD}	T _{vj} = 130 °C; d. c.		10	mA
R _{thjc}	cont. } sin. 180 } per thyristor/ rec.120 } per module		0,11/0,055 0,115/0,057 0,125/0,0625	°C/W °C/W °C/W
R _{thch}			0,08/0,04	°C/W
T _{vj} , T _{stg}			– 40 ... +130	°C
V _{isol}	a. c. 50 Hz; r.m.s.; 1 s/1 min		3600 / 3000	V~
M ₁	to heatsink SI (US) units		5 (44 lb.in.) ± 15 % ¹⁾	Nm
	to terminals SI (US) units		9 (80 lb.in.) ± 15 % ²⁾	Nm
a			5 · 9,81	m/s ²
w	approx.		430	g
Case	→ page B 1 – 88	SKKT: A 43	SKKH: A 56	

¹⁾ See the assembly instructions

²⁾ The screws must be lubricated

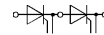

SKKT

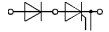

SKKH

Features

- Heat transfer through aluminium oxide ceramic isolated metal baseplate
- Chip soldered on direct copper bonded Al₂O₃ ceramic
- UL recognition, file no. E 63 532

Typical Applications

- DC motor control (e. g. for machine tools)
- Temperature control (e. g. for ovens, chemical processes)
- AC motor soft starters

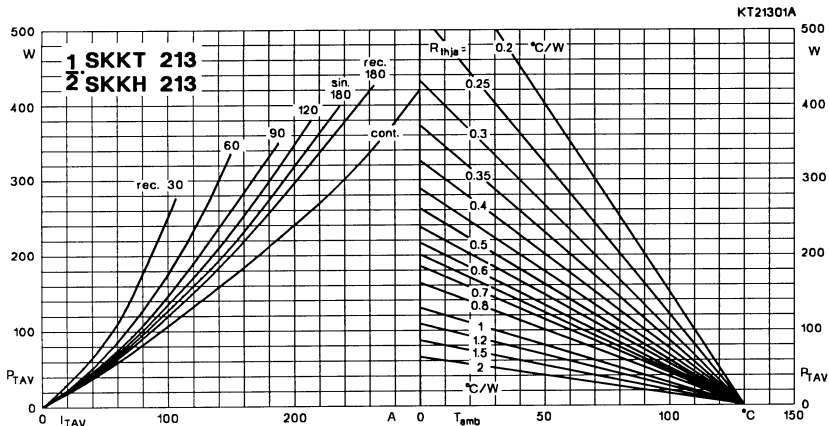

Fig. 1 a Power dissipation per thyristor vs. on-state current and ambient temperature

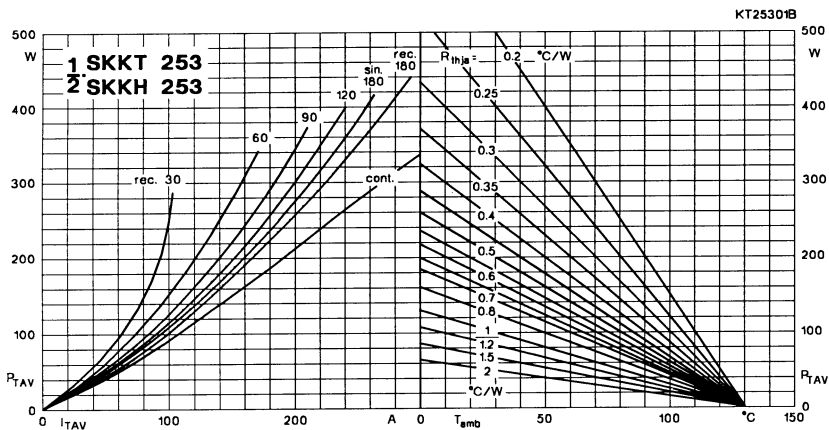

Fig. 1 b Power dissipation per thyristor vs. on-state current and ambient temperature

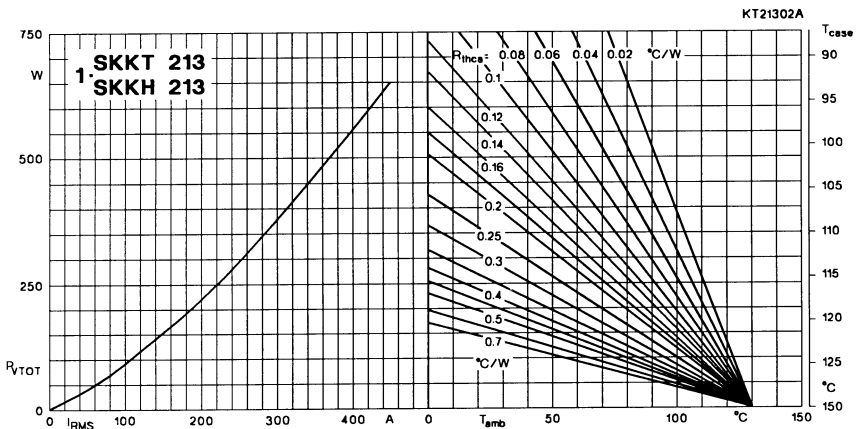

Fig. 2 a Power dissipation per module vs. rms current and case temperature

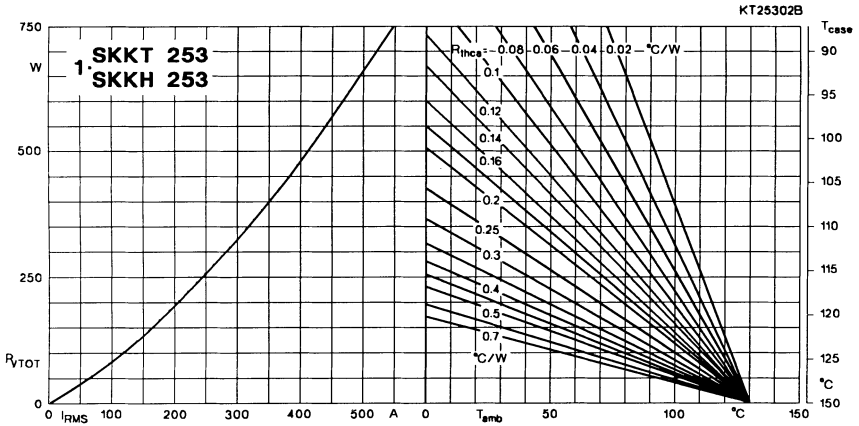

Fig. 2 b Power dissipation per module vs. rms current and case temperature

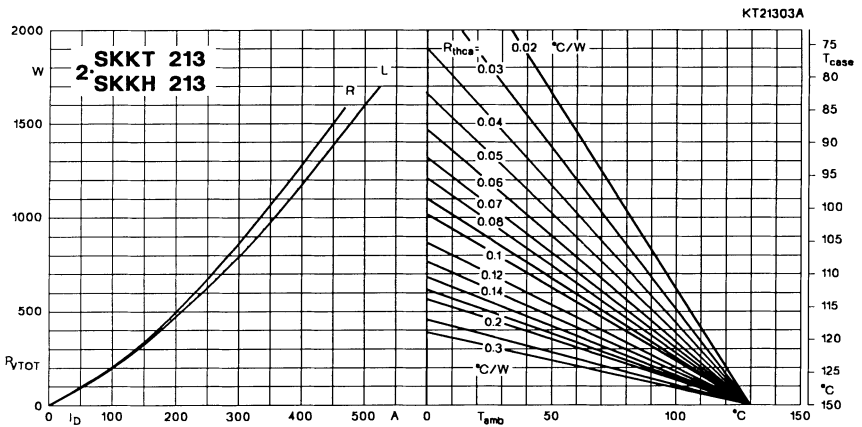

Fig. 3 a Power dissipation of two modules vs. direct current and case temperature

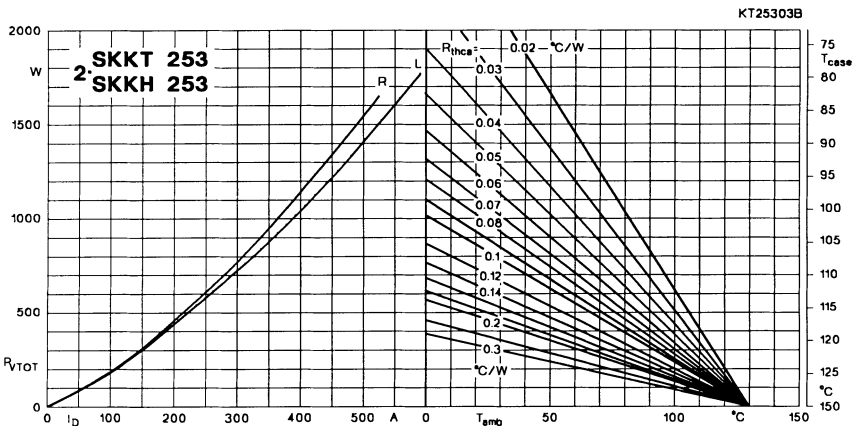

Fig. 3 b Power dissipation of two modules vs. direct current and case temperature

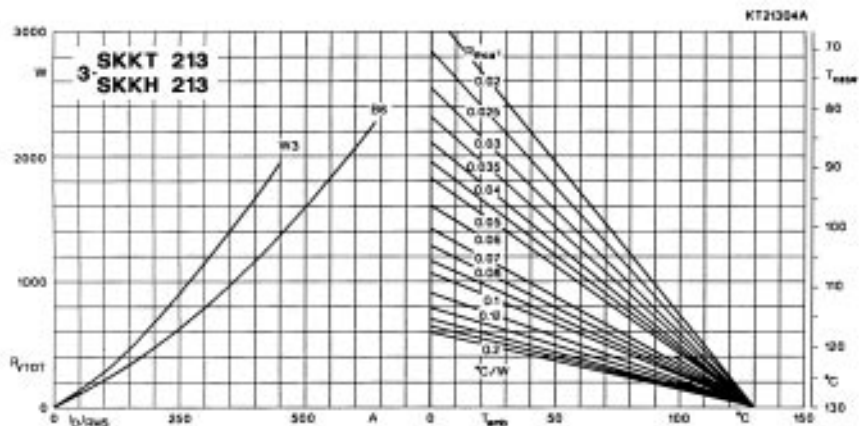

Fig. 4 a Power dissipation of three modules vs. direct and rms current and case temperature

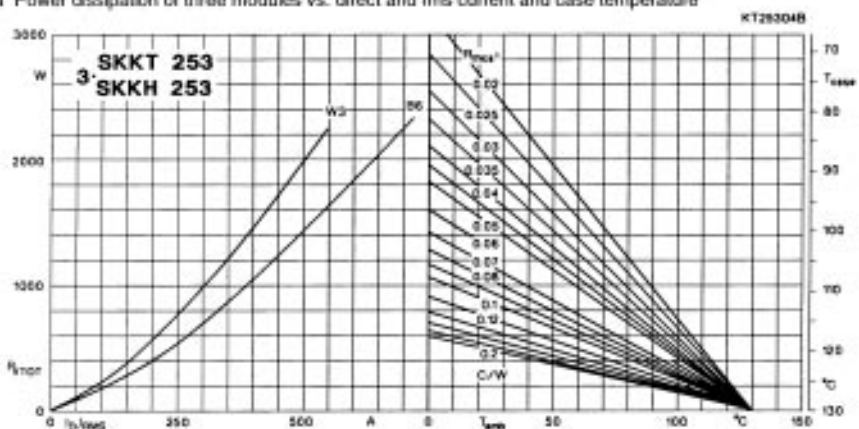

Fig. 4 b Power dissipation of three modules vs. direct and rms current and case temperature

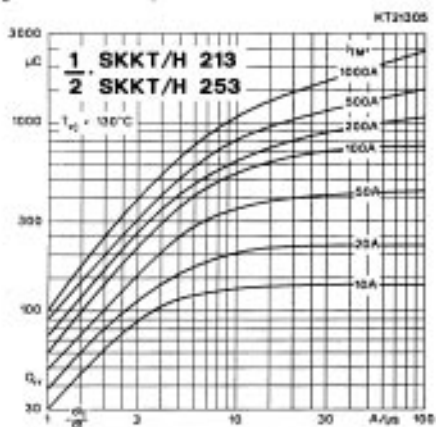

Fig. 5 Recovered charge vs. current decrease

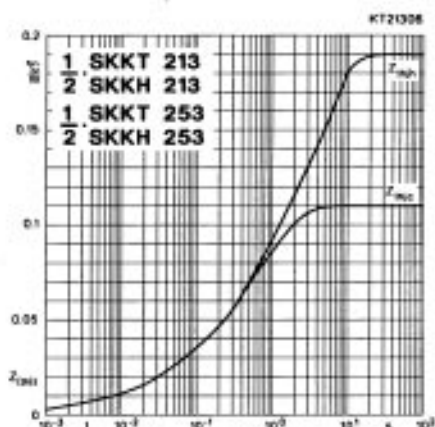

Fig. 6 Transient thermal impedance vs. time

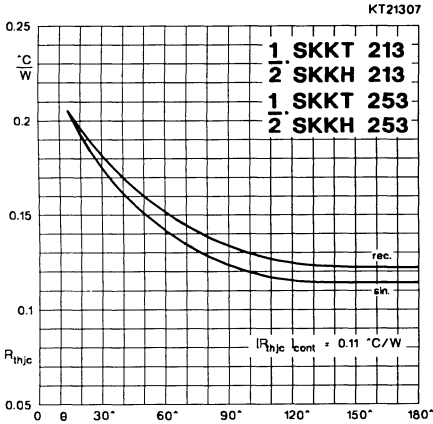

Fig. 7 Thermal resistance vs. conduction angle

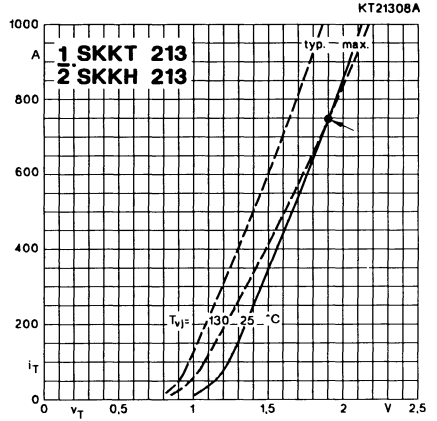

Fig. 8 a On-state characteristics

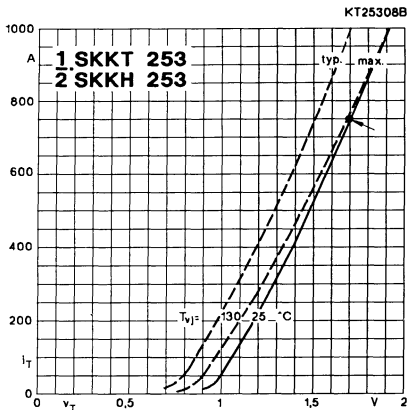

Fig. 8 b On-state characteristics

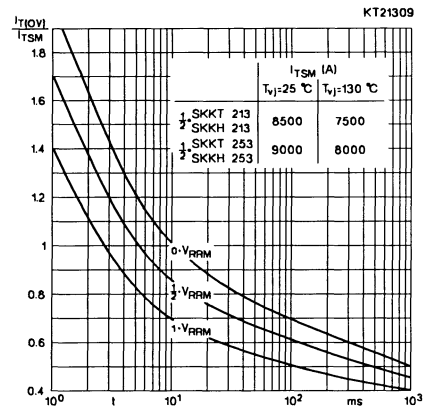

Fig. 9 Surge overload current vs. time

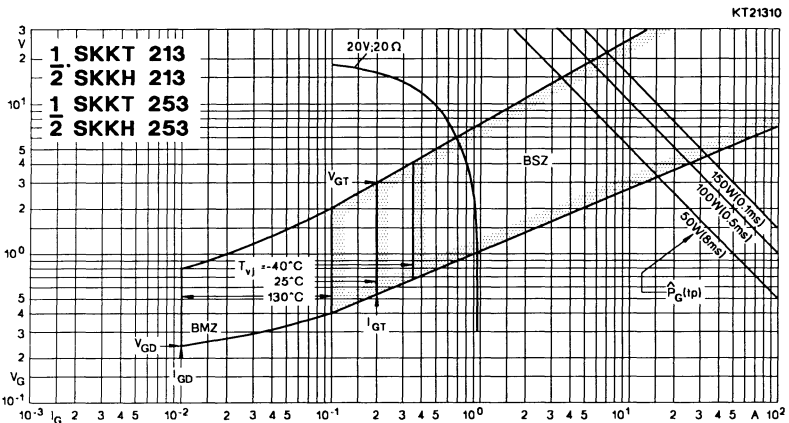
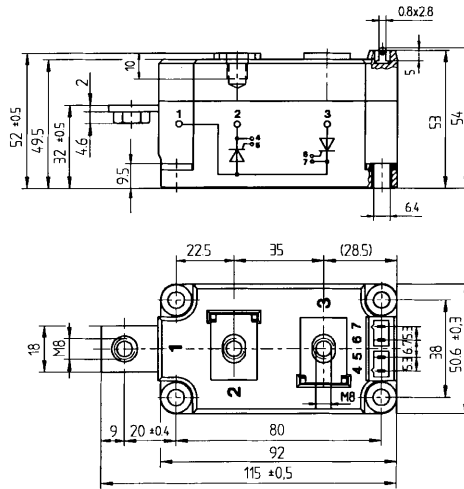

Fig. 10 Gate trigger characteristics

SKKT 213, SKKT 253

Case A 43

SEMIPACK® 3



Dimensions in mm

SKKH 213, SKKH 253

Case A 56

SEMIPACK® 3

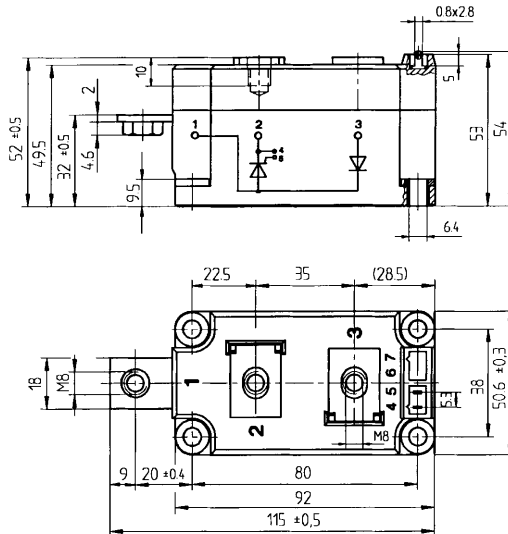

Dimensions in mm